

**Advanced high pressure seal technology**  
**Robust, compact & lightweight design**  
**Proven & reliable technology**  
**Maintenance & service friendly**  
**High flow rate exhaust function**  
**Minimal dead space volume (< 35ml)**  
**Optional adjustable pre-blow (P1) flow control unit**  
**Excellent response time & repeatability**  
**Low power consumption (2W)**



### Technical data

Switching functions:

Pre-blowing (P1) <sup>1)</sup>	2/2-way valve, normally closed
Blowing (P2) <sup>1)</sup>	2/2-way valve, normally closed
Exhaust (EXH)	2/2-way valve, normally open
<sup>1)</sup> with integrated non-return valve	

Operation:

Poppet valve, solenoid pilot actuated

Nominal size / Kv value:

	Nominal size	Kv
Pre-blowing (P1)	12mm	2.7 m <sup>3</sup> /h
Blowing (P2)	16mm	7.4 m <sup>3</sup> /h
Exhaust (EXH)	22mm	10.5 m <sup>3</sup> /h

Type of mounting:

Direct surface mounting or mounting on base plate

Medium:

Compressed air (purity class 7.4.4) <sup>1)</sup>  
 40µm filtered, non-lubricated  
<sup>1)</sup> acc. to ISO 8573-1:2001

Pre-lubrication:

USDA H1 compliant (registered NSF class H1)

Operating pressure (min...max):

Pre-blowing (P1)	2...20 bar
Blowing (P2)	3...40 bar
Pilot air supply (PAS)	6...7 bar

Port sizes (when fitted on base plate):

Pre-blowing (P1)	G1/2" female
Blowing (P2)	G3/4" female
Exhaust (EXH)	G1 1/4" female
Pilot air supply (PAS)	G1/4" female
Cavity (CAV)	G1" female

Pilot valves:

3/2 NO (P1, P2), 3/2 NC (EXH) sol/spring valve  
 24V DC / 2W, without manual override  
 Connector interface acc. to  
 15mm industry standard form C (9.4mm)

Maintenance free life time:

Typically exceeds 25 Million cycles

Temperatures:

Ambient temperature	0...+50°C
Medium temperature	+3...+30°C

### Typical application

Blowing block for stretch blow moulding machines.

For rotary and linear SBM machines.

Best suited for PET bottles up to 5 litres, depending on cycle time.

### Ordering information

For model numbers please refer to page 2.  
 3D CAD files are available on request.

### Materials

Aluminium parts:	anodised
Valve piston & seal:	FDA compliant synthetic material
O-rings:	NBR
Pilot protection device:	stainless steel
Screws:	steel, zinc coated
Retainer ring:	tempered spring steel
Spring:	stainless steel
Flow control bolt:	stainless steel
Blanking plug:	stainless steel

	<b>see page</b>
<b>Pneumatic diagram</b>	<b>2</b>
<b>Model numbers</b>	<b>2</b>
<b>Valve block dimensions</b>	<b>3</b>
<b>Accessories</b>	<b>6</b>

**Pneumatic diagram**

(Diagram shows PET blow valve block without base plate.)

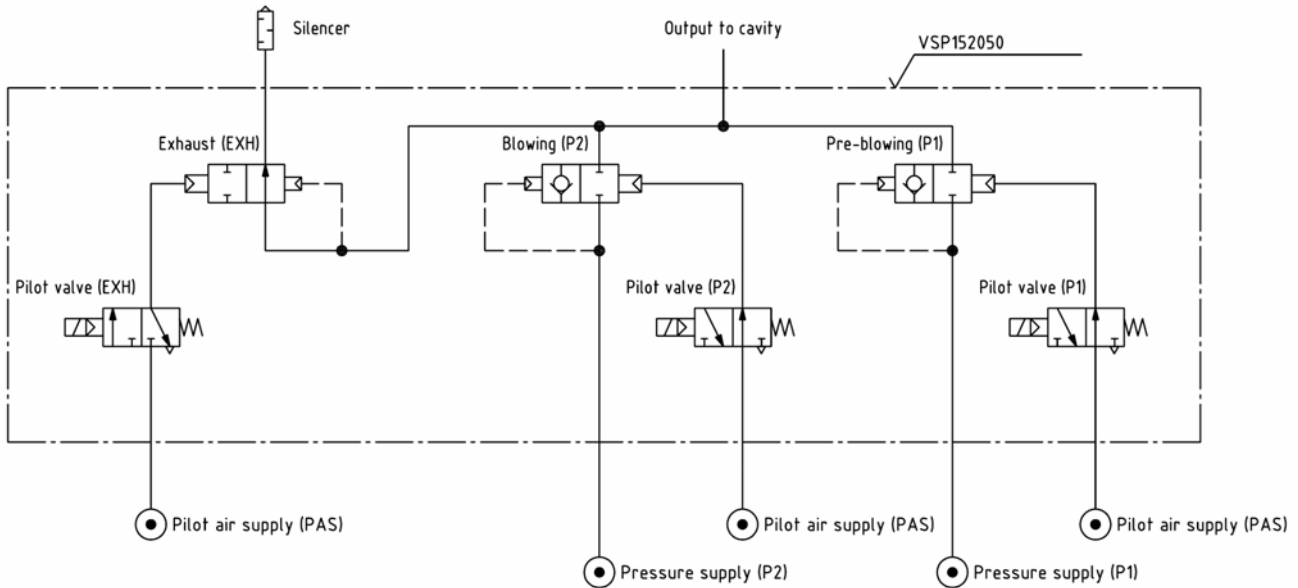

**Model numbers**

	Model	Description	Weight
	VSP152052	PET blow valve block on base plate working ports on bottom and on both sides <sup>1)</sup> including pre-blow (P1) flow control unit <sup>2)</sup>	6.0 kg
	VSP152051	PET blow valve block on base plate working ports on bottom and on both sides <sup>1)</sup> (without flow control unit) <sup>3)</sup>	5.8 kg
	VSP152055	PET blow valve block on base plate working ports on bottom only	4.1 kg
	VSP152050	PET blow valve block (without base plate)	2.6 kg

<sup>1)</sup> Base plate supplied with blanking plugs for unused ports.

<sup>2)</sup> For detailed description on pre-blow (P1) flow control unit please refer to the maintenance and instruction manual (ref. no. VSP152099).

<sup>3)</sup> Blanking plate is fitted in place of pre-blow flow control unit.

For part numbers on accessories please refer to pages 6...10.

For part numbers on spare and wear parts as well as for data on response times and repeatability please refer to the maintenance and instruction manual (ref. no. VSP152099).

**Dimensions**

VSP152052 – PET blow valve block on base plate including pre-blow (P1) flow control unit  
 VSP152051 – PET blow valve block on base plate without pre-blow (P1) flow control unit

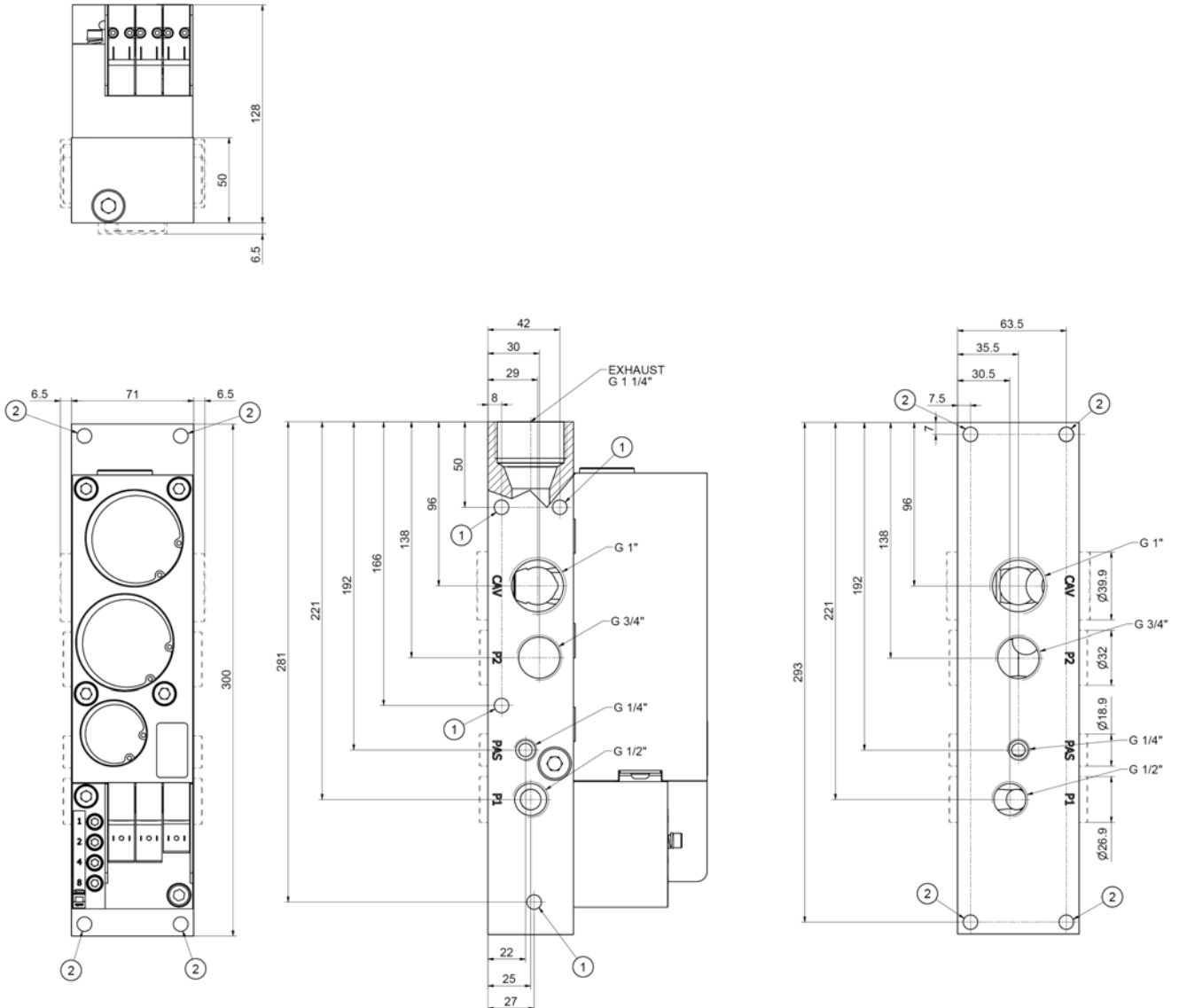

- ① Straight screw holes for side mounting =  $\varnothing$  8.5mm (max. M8 screws)
- ② Straight screw holes for bottom mounting =  $\varnothing$  8.5mm (max. M8 screws)

**Note:**

Drawing shows model VSP152052.

Dotted lines in drawing show blanking plugs fitted on bottom and/or side ports.

All dimensions in mm

## Dimensions

### VSP152055 – PET blow valve block on base plate (bottom ports only)

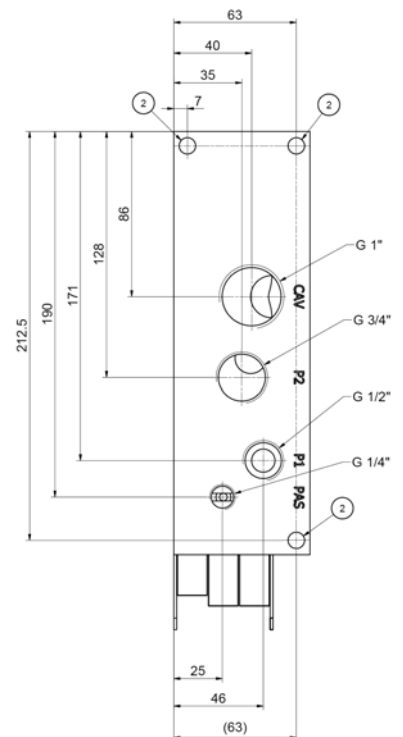
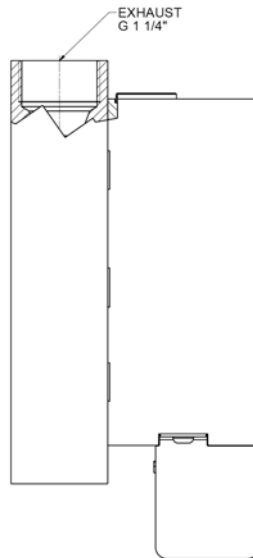
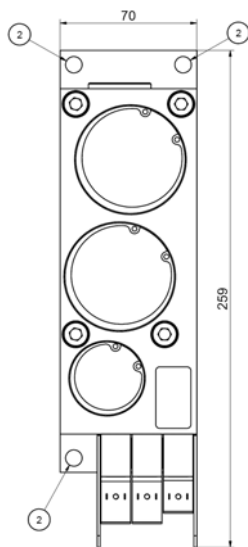
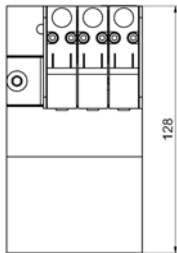

② Straight screw holes for bottom mounting =  $\varnothing$  8.5mm (max. M8 screws)

All dimensions in mm

**Dimensions**

**VSP152050 – PET blow valve block (without base plate)**

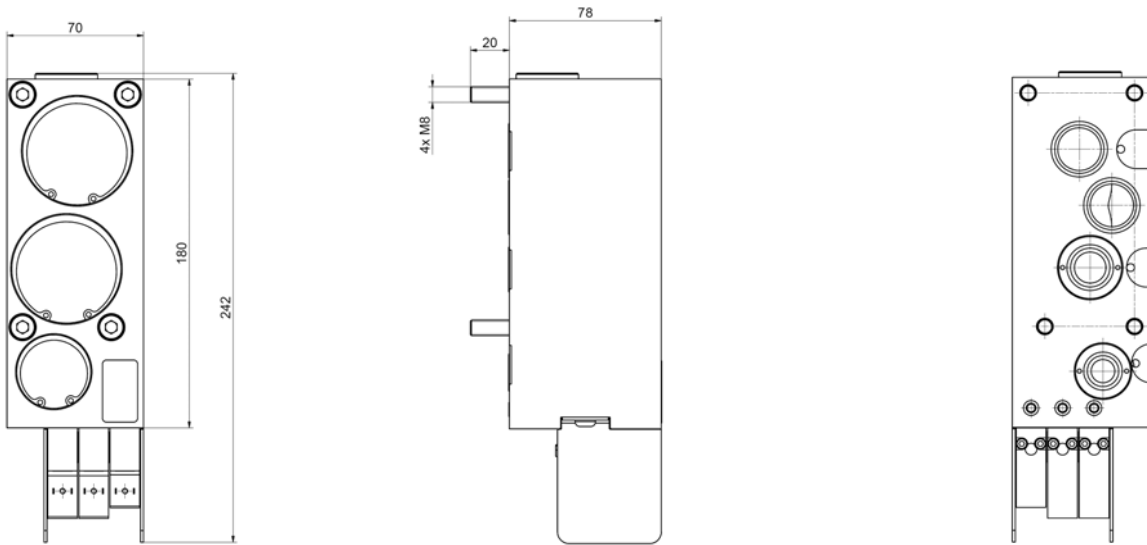
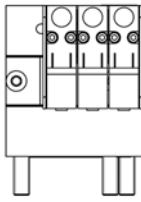

**Note:**

A base plate with corresponding interface and surface roughness is required for mounting and operation of this valve block. Please comply with below information:

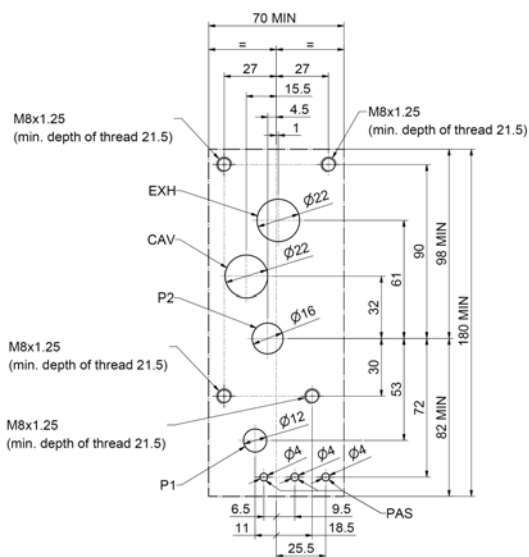

Torque M8 screws = 25 Nm  
 Flatness on whole interface = 0.2  
 Surface finish on whole interface = Ra1.6

All dimensions in mm

## Accessories

### Silencer

	Model	Description	Weight
	T30BA800	40bar Silencer with R1 1/4" connection (male)	2.1 kg

### Technical data

Max. operating pressure:  
40 bar

Size:  
R1 1/4"

ID port:  
33mm

Flow factor:  
Conductance C (ISO 6358): 170 dm<sup>3</sup>/s\*bar

Operating temperature:  
0...+80°C

Sound pressure level (SLeq at 1m from source):  
Measured at 5 bar: 90 dBA  
Maximum peak at 40 bar: 117 dBC

Exhaust time for free silencer (measured at 40bar):

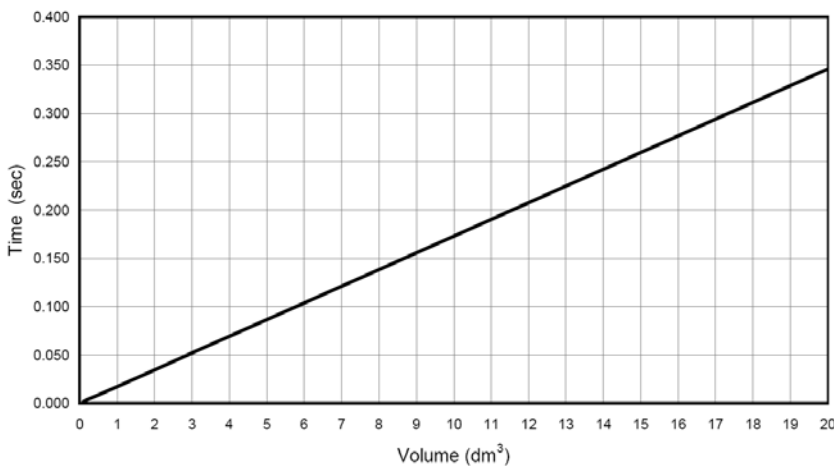

Volume to be exhausted (dm <sup>3</sup> )	Exhaust time (sec) (95%)
0.1	0.002
0.2	0.003
0.5	0.009
1	0.017
2	0.035
3	0.052
4	0.069
5	0.087
10	0.173
20	0.346

**Note:**

Silencer fitted directly on capacity.  
Restriction between capacity and silencer will introduce additional time.  
Limitation of all components in the system have to be considered for the resulting exhaust time.

**Accessories**

**Silencer**

**Dimensions**

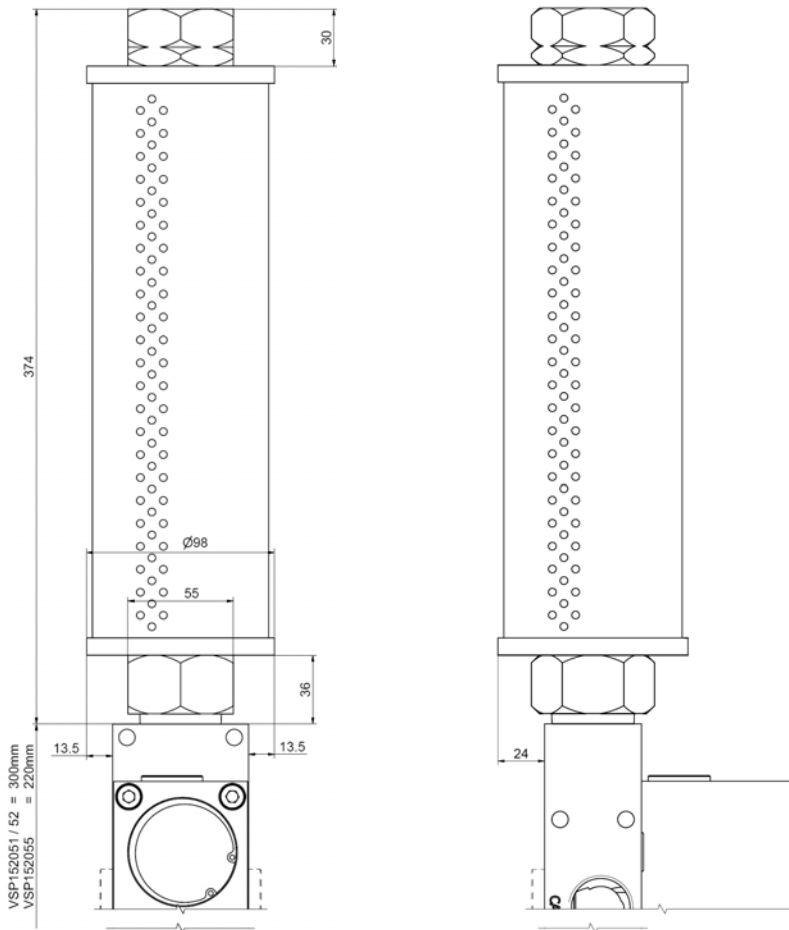

**Note:**  
Drawing shows silencer mounted to base.  
Additional height to unscrew silencer = + 20mm

All dimensions in mm

**Accessories**

**Pressure transmitter**

	Model	Description	Weight
	VSP152069	40bar Pressure transmitter with thin film technology M12x1, 4-pin circular connector, IP67 (IEC 60529) Pressure connection G1/4" (DIN 3852-E)	0.06 kg

For detailed description on pressure transmitter please refer to the operating instruction manual (ref. no. VSP152097).  
Adaptor for fit pressure transmitter to cavity port in base available (model no. VSP152076). Please refer to page 9 for details.

**Technical data**

Pressure:		Electrical characteristics:	
Pressure range	40 bar	Signal output	4...20 mA, 2-wire
Over pressure safety	80 bar	Power supply $U_B$	8...36 V DC
Burst pressure	400 bar	Maximum load $R_A$	$R_A \leq (U_B - 8 V) / 0.02 A$

Response time (10...90%):	≤ 2 ms	Dielectric strength:	500 V DC
---------------------------	--------	----------------------	----------

Reproducibility:	≤ 0.3 % of span	1-year stability:	≤ 0.3 % of span (at reference conditions)
------------------	-----------------	-------------------	---

Materials:	
Wetted parts	stainless steel
Case	highly resistive, fibreglass-enforced plastic (PBT)

Accuracy:  
 ≤ 0.5 % of span (BFSL)  
 ≤ 1.0 % of span (BFSL) for pressure ranges ≤ 10 bar  
 ≤ 1.0 % of span (limit point calibration)  
 ≤ 2.0 % of span (limit point calibration) for pressure ranges ≤ 10 bar  
 Including linearity, hysteresis and repeatability

Temperature range:	
Medium temperature <sup>1)</sup>	-40...+125°C
Ambient temperature <sup>1)</sup>	-40...+100°C
Storage temperature <sup>1)</sup>	-40...+120°C
<sup>1)</sup> Also complies with EN 50178, Tab. 7, Operation (C) 4K4H, Storage (D) 1K3, Transport (F) 2K3	
Compensated temperature	0...+80°C

Temperature coefficients in compensated temperature range:	
Mean TC of zero	≤ 0.3 % of span / 10K (for special pressure ranges increased TC of zero)
Mean TC of range	≤ 0.2 % of span / 10K

CE conformity:  
 89/336/ewg interference emission and immunity  
 see EN 61 326, interference emission limit class A and B  
 97/23/EG pressure equipment directive

Wiring protection:  
 Protected against short circuiting Sig+ against  $U_B$ -0V and reverse polarity for power supply except ratiometric output signals



**Accessories**

**Pressure transmitter**

**Dimensions**

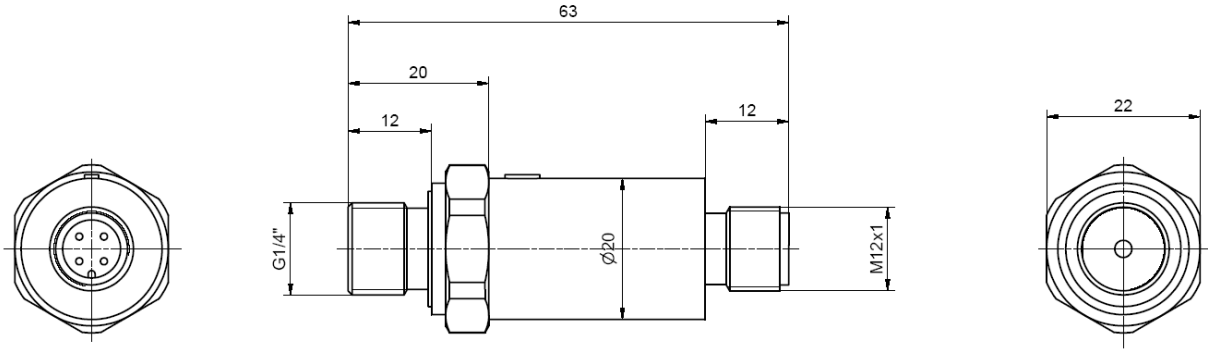

**Wiring information**

Circular connector, 4-pin / 2-wire

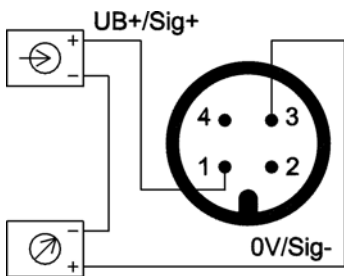

**Legend**

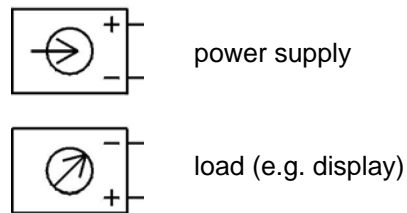

**Installation on base**

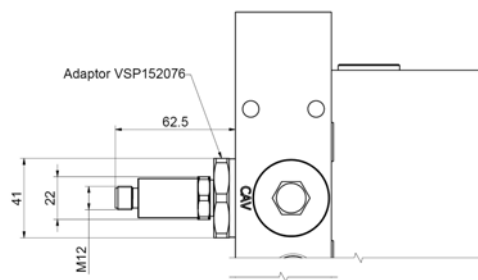
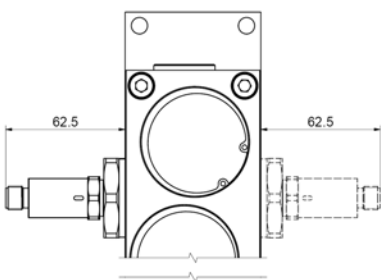

**Note:**  
Drawing shows pressure transmitter with adaptor VSP152076 fitted on left or right cavity port.



**Note:**  
Drawing shows pressure transmitter with adaptor VSP152076 fitted on bottom cavity port.

For detailed drawing of adaptor VSP152076 please refer to operating instruction manual (ref. no. VSP152097).

All dimensions in mm

## Accessories

### Plug options

	Model	Description	Weight
	0589431	15mm plug with cable gland (incl. gasket and mounting screws)	0.01 kg
	0589433	15mm plug with moulded cable (incl. gasket and mounting screws) cable length 2m	0.10 kg

### Technical data

Voltage:  
24V DC

Indication:  
LED yellow

Connector interface:  
Industry standard form C (9.4mm)

Protection class:  
IP65

Surge suppression:  
Z-Diode

Wiring diagram:

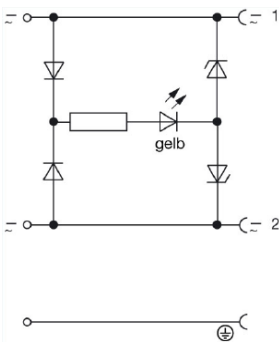

### Warning

These products are intended for use in industrial compressed air systems only. Do not use these products where pressures and temperatures can exceed those listed under 'Technical data'.

Before using these products with fluids other than those specified, for non-industrial applications, life-support systems, or other applications not within published specifications, consult NORGREN. Through misuse, age, or malfunction, components used in fluid power systems can fail in various modes.

The system designer is warned to consider the failure modes of all component parts used in fluid power systems and to provide adequate safeguards to prevent personal injury or damage to equipment in the event of such failure.

**System designers must provide a warning to end users in the system instructional manual if protection against a failure mode cannot be adequately provided.**

System designers and end users are cautioned to review specific warnings found in instruction sheets packed and shipped with these products